

REVISIONS		DATE	APPROVED
ZONE	REV.	DESCRIPTION	

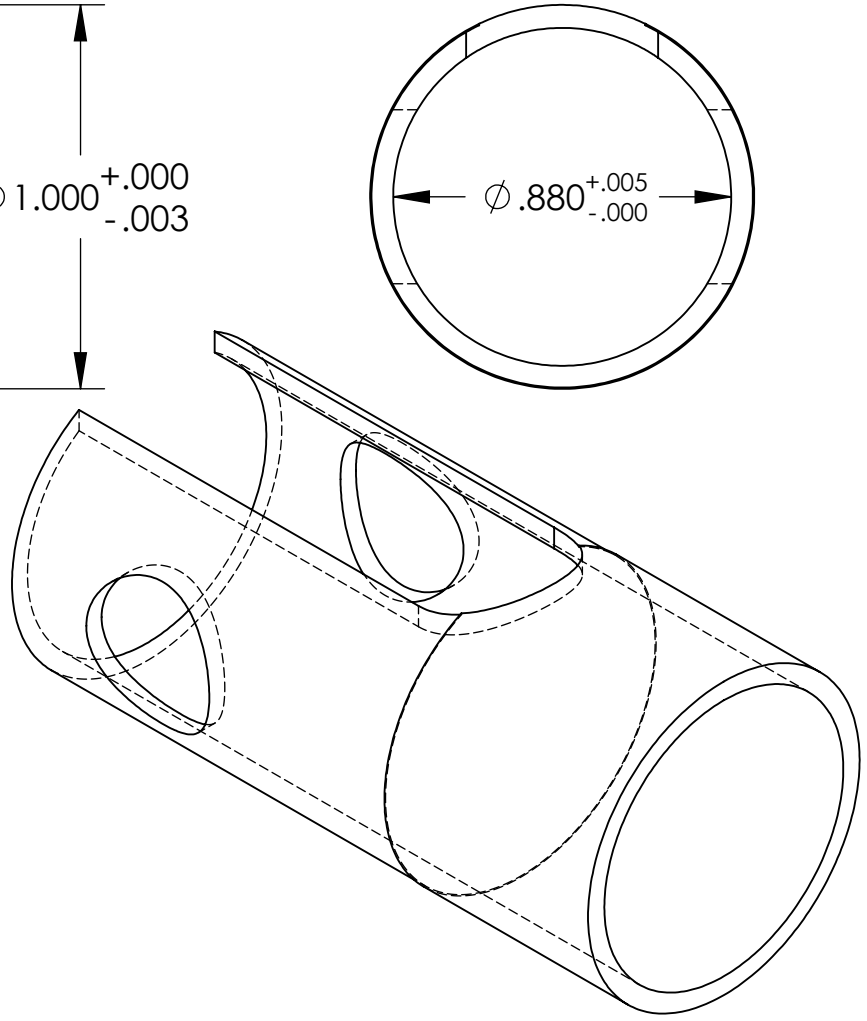
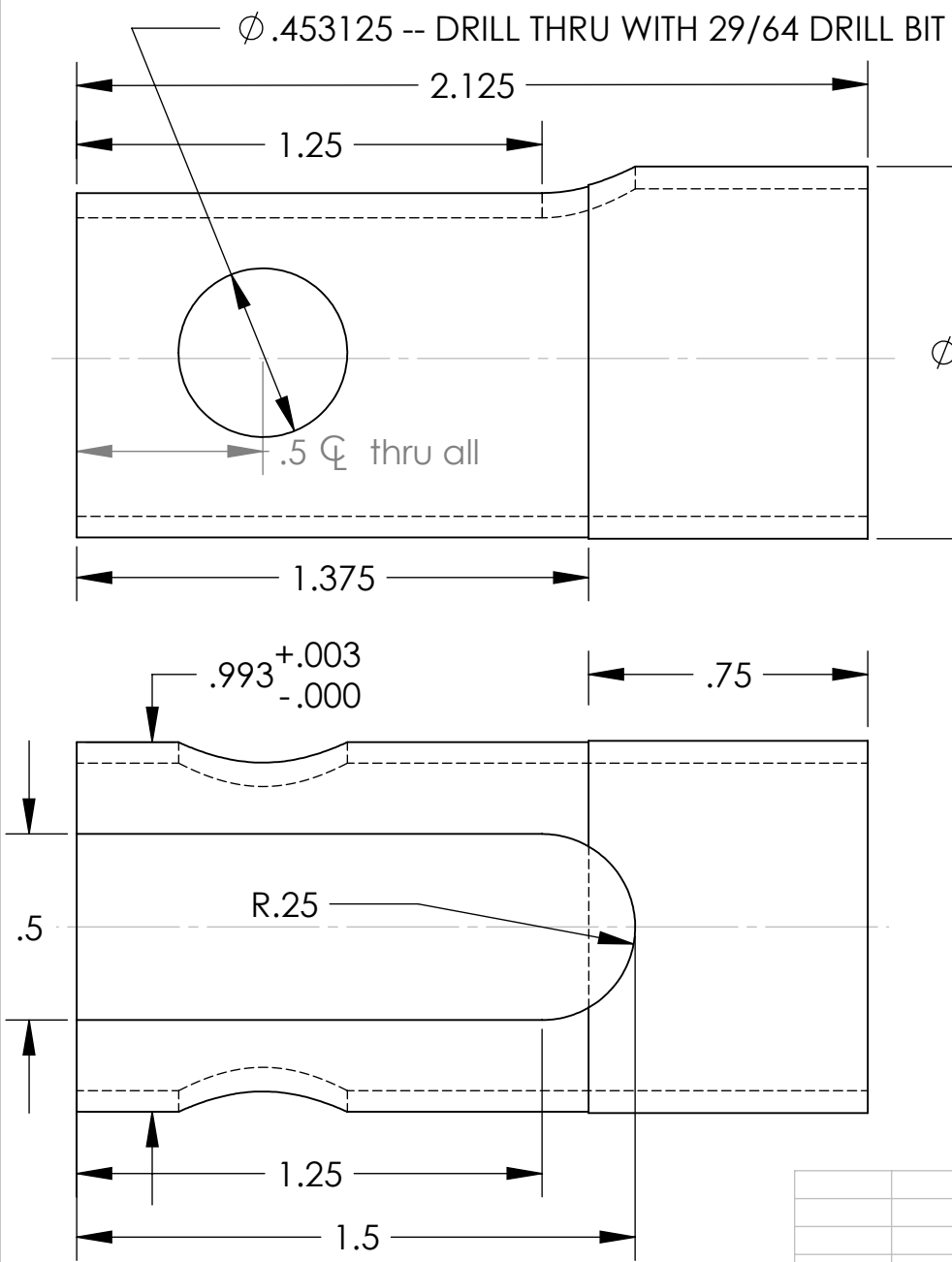

PROPRIETARY AND CONFIDENTIAL
 THE INFORMATION CONTAINED IN THIS DRAWING IS THE SOLE PROPERTY OF INFINITY Aerospace. ANY REPRODUCTION IN PART OR AS A WHOLE WITHOUT THE WRITTEN PERMISSION OF INFINITY Aerospace IS PROHIBITED.

DIMENSIONS ARE IN INCHES		NAME	DATE
TOLERANCES:		DRAWN	JDN 10/23/01
FRACTIONAL \pm		CHECKED	
ANGULAR: MACH \pm BEND \pm		ENG APPR.	
TWO PLACE DECIMAL $\pm .01$		MFG APPR.	
THREE PLACE DECIMAL $\pm .005$		Q.A.	
MATERIAL		COMMENTS:	
6061-T6 Aluminum			
FINISH		--	
NEXT ASSY	USED ON		
APPLICATION		DO NOT SCALE DRAWING	

INFINITY Aerospace

Custom .875 ID
 Stick Grip Spacer

SIZE	DWG. NO.	REV.
A		
SCALE:2:1	WEIGHT:	SHEET 1 OF 1