

REV	DESCRIPTION	ECO#	DATE
2	ADDED LEFT VIEW	JHM	
3	UPDATED ASSEMBLIES	JHM	
4	UPDATED ASSEMBLIES	JHM	12 JUN 04
5	UPDATED ASSY'S	JHM	28 SEP 04

### TYPICAL BOTTOM VIEW

OF CENTER HOT

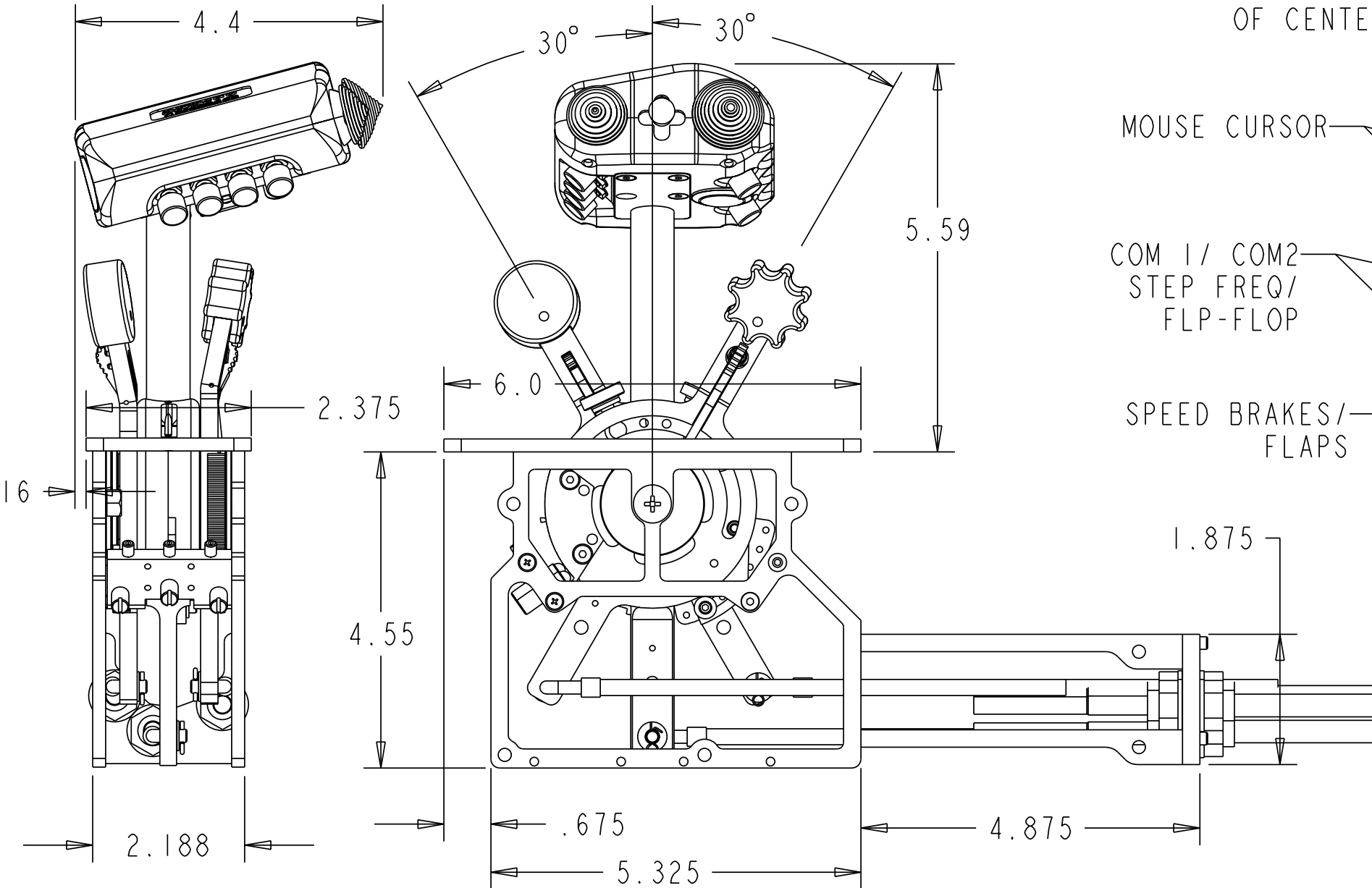
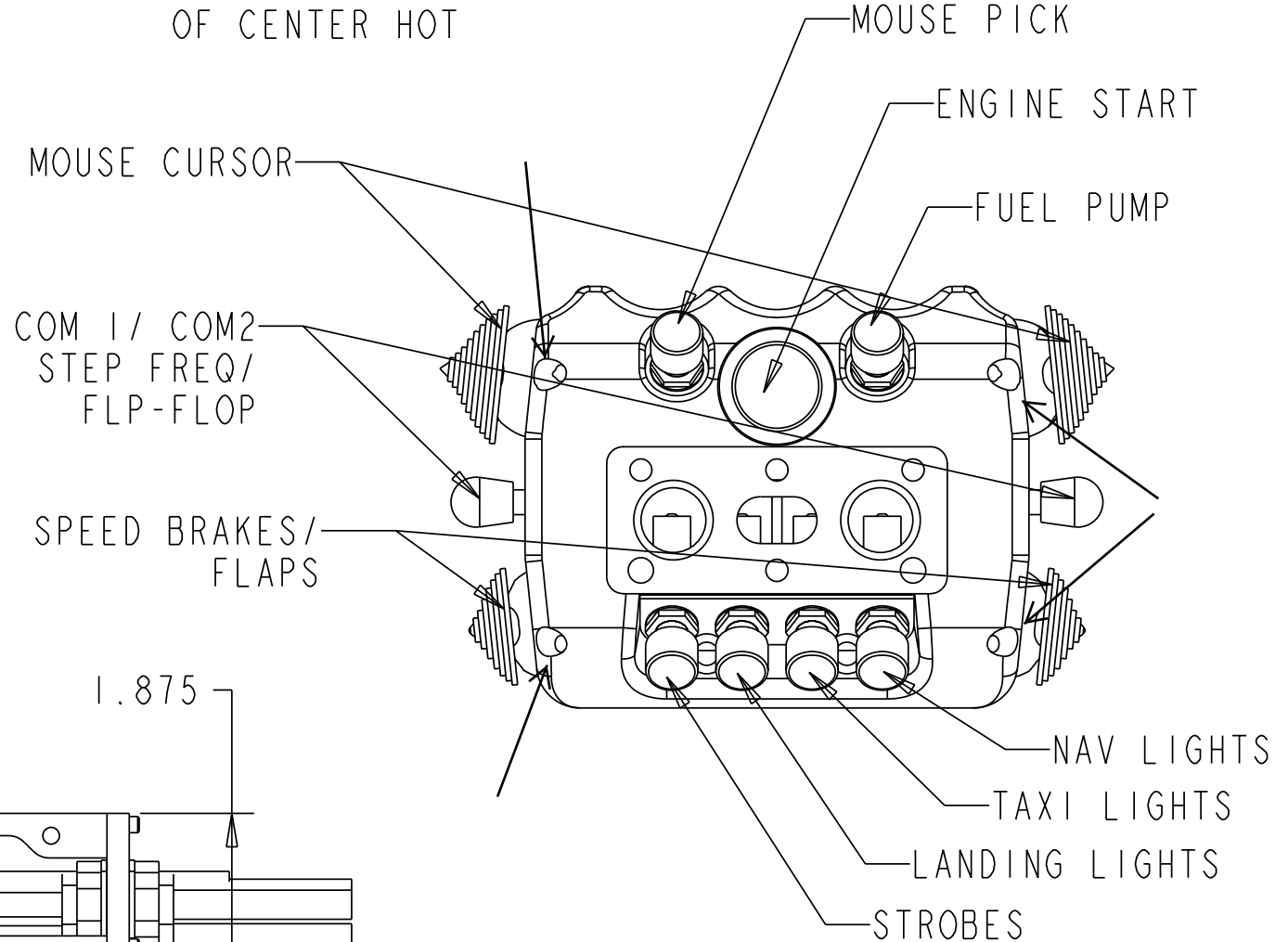

### TYPICAL LEFT HAND HOT

FOR TRACTOR AIRCRAFT  
W/ CABLECRAFT CABLES

<b>TOLERANCES</b> (EXCEPT AS NOTED) DO NOT SCALE ANGLES +/- 1° FRAC +/- 1/32 .XX +/- .01 .XXX +/- .005		<b>INFINITY Aerospace</b> 1750 JOE CROSSON DRIVE, #D-2, EL CAJON, CA 92020 Phone (619) 448-5103 Fax (619) 448-5176	
DRAWN J.H. Monti CHKD J.D. Newman APPD	SCALE 0.750:1 DATE 12 JUN 02	MATL SEEN/NOTE FINISH SEEN/NOTE CAD SOFTWARE PRO-E	DRAWING NO. - - - SHEET 1 OF 1
TITLE <b>GRIP &amp; OTRHOS</b>		SIZE B	DRAWING NO. - - -
MODEL FILE GRIP-4SIDE		SHEET 1 OF 1	
THE DRAWINGS AND INFORMATION CONTAINED HEREIN IS OWNED SOLELY BY INFINITY Aerospace. ANY COPYING OR OTHER USE OF THE INFORMATION WITHOUT INFINITY Aerospace's WRITTEN AUTHORIZATION IS STRICTLY PROHIBITED. CONFIDENTIAL / COMPANY PROPRIETARY			